

X-STREAM® vs. POWER SOAK

	X-STREAM®	POWER SOAK
Trapezoid Tank Design	YES	NO
Dual Pumps	YES	NO
Intelligent Control Display	YES	NO
Variable, Programmable Wash Schemes	YES	NO
Slow Speed Idle Mode	YES	NO
Data Reporting Package	YES	NO
4 Different Languages	YES	NO
Plug n' Play Components	YES	NO
Removable Discharge Plates	YES	NO
Whirl Pool Tank Action	YES	NO
Wash Tank Depth	18"	21"
Standard Heating Element	2,500 watts	7,000 watts



X-STREAM® WASH SYSTEM

Quickly and efficiently turns around clean, sanitized items and allows you to focus on the business of serving your customers.

X-STREAM® CONTROLLER COMPARISON

	K-1000	K-5000
Variable Speed	NO	YES
Number of Speeds	1	5
Cycle Time(s)	4 hrs.	5 timed, programmable cycles
Language(s)	English	English, French, Spanish, Italian
Temperature Control	YES	YES
Low Water Detection	YES	YES
Change Water Indicator	YES	YES
Integrated Soap Dispensing	YES	YES
Plug n' Play Components	YES	YES
Self Diagnostics	Limited	Full
Idle Speed	NO	YES
Data Reporting Package	NO	YES
Integrated Heated Sanitizer	NO	YES

Duke Manufacturing Co.

2305 N. Broadway
 St. Louis, MO 63102
 Toll Free: 800 735 3853 • Phone: 314 231 1130
www.dukemfg.com

X-STREAM® WASH SYSTEM

X-STREAM® IS THE BEST PERFORMING, EASIEST TO USE POWER WASH SINK SYSTEM WITH THE LOWEST TOTAL COST OF OWNERSHIP

Foodservice operations are switching to a power wash sink to tackle the undesirable task of pot and pan washing. This in turn is leading to increased operational efficiency and an improvement in the bottom line. The X-Stream® Wash system quickly and efficiently turns around clean, sanitized items and allows you to focus on the business of serving your customers.

X-STREAM® WASH SYSTEM INTELLIGENT CONTROL CENTER

The X-Stream® Wash System increases the ease and effectiveness of your warewashing process by delivering the right amount of heat, chemical and impingement for each job.

- Variable, programmable wash schemes tailored to your operations
- Batch cycle washing notifies you when your wares have been thoroughly cleaned
- Idle mode between batches reduces energy costs and eliminates grease slicks resulting in possible recontamination during ware removal
- Health reporting allows you to track and monitor usage data to ensure proper sanitation
- Other valuable features include temperature control, low water detection, integrated soap dispensing and self diagnostics

KEY FEATURES

PLUG N' PLAY SERVICEABILITY:

- Main components can be replaced in 15 minutes or less (control, heater and pumps)
- Replacement parts require only a nut driver and/or wrench - no service call needed

RIBBED VACUUM BREAKER:

- Efficient flow design
- Prevents pots and pans from sticking to the intake

TRAPEZOID WASH TANK:

- Excellent impingement without hazardous splashing
- Angled header wall allows total tank drainage to eliminate contamination
- Shallow depth increases ergonomics and reduces utility costs
- No need for wash tank inserts

DUAL PUMP DESIGN:

- Superior cleaning performance through multi-sided discharge
- Increased energy savings due to kinetic heat transfer

DISCHARGE PLATES:

- Removable and easy to clean
- Ability to tailor wash tank performance to your needs

OPTIONS AND ACCESSORIES

- Adjustable sheet pan system
- Integrated soap pump
- Utensil basket
- Pocketed backsplash
- Removable folding lid system
- Dish machine (X-Clean®)

RETURN ON INVESTMENT

In addition to a safe, sanitary kitchen environment, the following benefits are attributable to the X-Stream® Wash System:

- **Labor savings** through automation, multi-tasking and elimination of redundant processes
- **Cost reduction** through energy savings, water usage reduction, efficient chemical usage and extended life of foodservice consumables
- **Improved morale** as one of the least favored jobs becomes a seamless task
- **Lower risk** to your operations due to less splashing and optional reporting capabilities

- 1 Intelligent Control Center
- 2 Plug n' Play Serviceability
- 3 Ribbed Vacuum Breaker
- 4 Trapezoid Wash Tank
- 5 Dual Pump Design
- 6 Discharge Plate

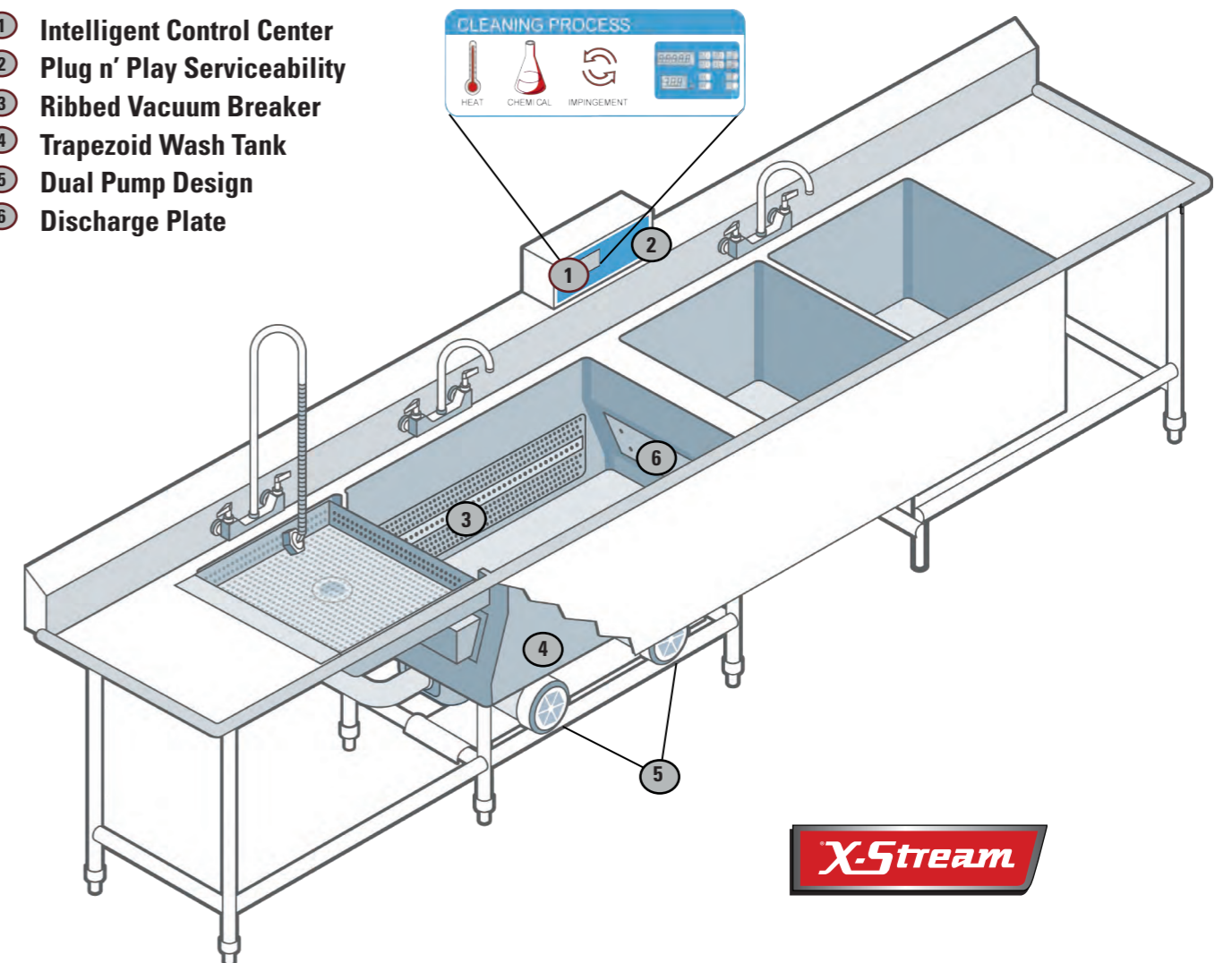

X-STREAM® WASH ACTION

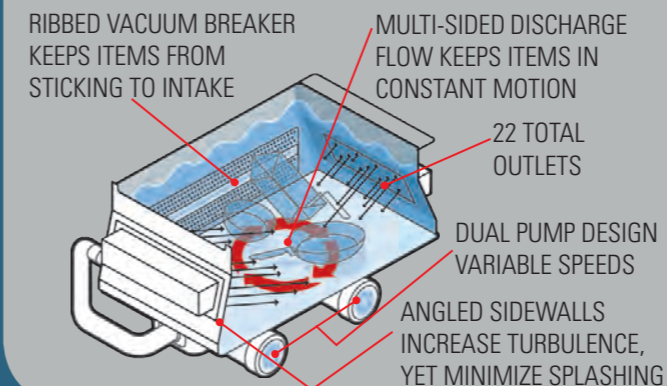

COMPETITOR WASH ACTION

