



Specifications

F.O.B St. Louis, Missouri 63102



613-E2
(shown w/optional casters)

OPTIONS:

- Stainless steel interior
- Stainless steel back enclosure panel
- Seismic feet
- High Voltage (380/415/440/480)
- Casters
- Porcelain drip tray
- Double stack - shipped assembled
- Extra oven racks - standard and deep depth
- Prison package - tamper proof screws, lexan hinged cover with lockable clasp
- Extended warranty

AGENCY LISTINGS:



DUKE MANUFACTURING CO.
2305 N. Broadway
St. Louis, MO 63102

800.735.3853 Toll Free
314-231-1130 In Missouri
314.231.5074 Fax
www.dukemfg.com

Approval Stamp(s):

PRODUCT INFORMATION:

PROJECT: _____
ITEM: _____
QUANTITY: _____

MODEL:

Duke Convection Ovens
Double Section - Standard Depth - Electric

- 613-E2** Double section, standard depth

STANDARD FEATURES:

- 6 racks/13 rack positions
- Porcelain interior finish
- 65/35 stainless steel doors - chain driven
- Double pane glass in 65 door
- 8" angular stainless steel legs/adjustable feet

OVEN SECTION:

- Stainless steel front, sides and top
- 1-1/2" insulation on bottom, sides and back
- 3" insulation on top

OVEN CONTROLS:

- "V" - Basic snap action thermostat (200° - 500°F), 60 minute electric dial timer with continuous sound buzzer, 2-speed fan
- "XX" - Solid state digital time and temperature controls, 12-hour countdown timer, **Cook and Hold** feature, 2-speed fan, Pulse fan capability
- "ZZ" - 10 programmable menu buttons, 5-rack ID timers, computerized digital time and temperature controls, Cook and Hold feature, 2-speed fan, Pulse Fan capacity

SHORT FORM SPECIFICATIONS:

Duke Convection Ovens - Electric - Double Section - Standard Depth. Front, sides, top, door, interior door liners and door gaskets shall be constructed of stainless steel. 20% larger interior cavity than industry standard. Porcelain interior finish, with 6 racks and 13 rack position, and 7/8" coved corners. Unit shall have simultaneously opening doors and 8" angular stainless steel legs with adjustable feet. Unit shall have 65/35 chain driven stainless steel doors with double pane glass in 65 door. Doors shall be mounted on full length solid steel shafts and bronze bushings. Interior lighting to be (2) 50 watt, 115v bulbs. Bottom, sides and back shall be fully insulated with 1-1/2" thick insulation, top to have 3" thick insulation. Units shall have 11 KW input with 1/2 HP, 2-speed blower motor. An ON-OFF-COOL DOWN switch shall be supplied. Unit to be fused to protect against overload. Overall dimensions of unit shall be: 70-1/2" height, including 8" legs, 38" width, depth of 39-1/2" and cavity dimensions of 29"W x 24"H x 24"D.

DUKE CONVECTION OVENS - DOUBLE - STANDARD DEPTH - ELECTRIC

Catalog No. DCO-ELECD5

A.I.A. File No. 35-C-13

DUKE CONVECTION OVENS
DOUBLE SECTION - ELECTRIC - STANDARD DEPTH

□ **613-E2** Double section, standard depth

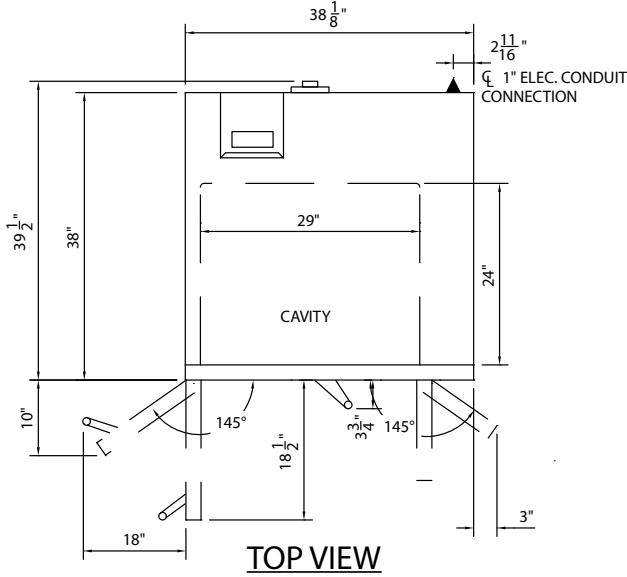

Electrical Specifications - Per Section				
	208V Amps	240V Amps	480V Amps	KW
1 Phase	52.8	45.8	n/a	10.0
3 Phase	30.5	26.5	13.3	10.0

▲ - Electronic connection point

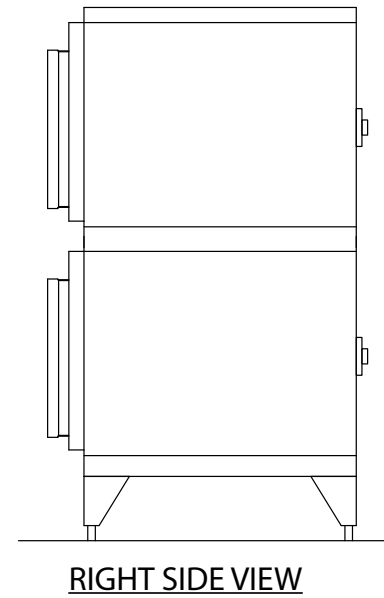
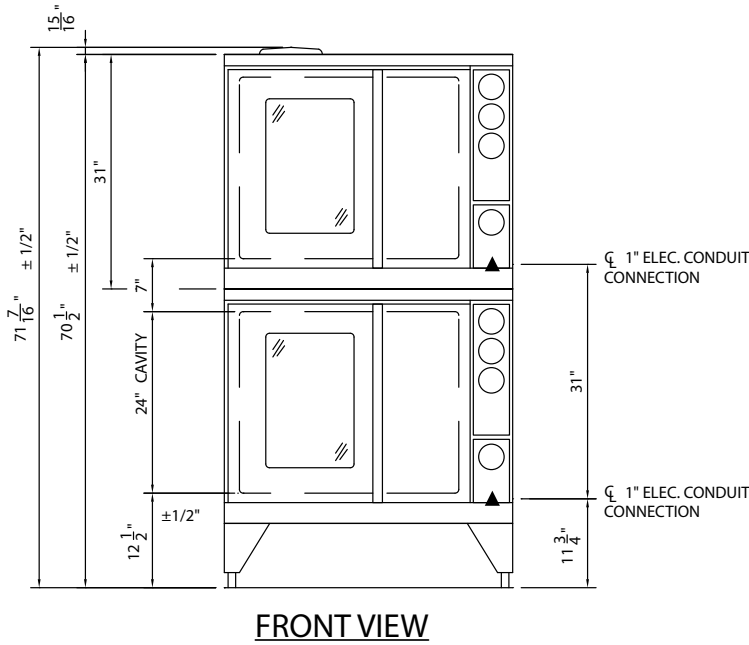

DIMENSIONS:

FREIGHT CLASS: 85

Model	Depth front view		Width		Height top view		Cube ft. crated	Weight	
	in	cm	in.	cm	in.	cm		lbs	kg
613-E2	39-1/2	100.3	38	96.5	70-1/2	179.1	69.7	1020	464.0

DUKE MANUFACTURING CO.

2305 N. Broadway
 St. Louis, MO 63102

800.735.3853 Toll Free
 800.231.1130 In Missouri
 314.231.5074 Fax
www.dukemfg.com



Specification subject to change