



FR2 HYDRO-HEATER FOOD RETHERMALIZERS / BAIN-MARIE HEATERS

Models FR2-3, -4, -6 FR2-3B, -4B, -6B, -9B

The Hatco Hydro-Heater is a state-of-the-art, high efficiency circulation water heater, using a combination of "free-flow" technology and advanced electronic controls for circulating hot water by natural convection in a sink for reconstituting frozen foods.

This heater features a tubular water chamber with heating elements uniquely wrapped outside the flow tube so elements do not come in direct contact with the water. The design eliminates sediment and lime buildup on the element, resulting in longer life. A special electronic controller maintains the setpoint temperature assuring a responsive and efficient operation.

FLEXIBILITY

As a food reconstitutor, the Hydro-Heater FR2 heats or holds food at safe temperatures between 140°F and 190°F (60°-88°C).

QUALITY

The following features assure the finest performance for years to come:

- Utilizes "free-flow" technology and advanced electronic controls to assure a responsive and efficient operation.
- All models include a stainless steel front, powdercoated body, convenient drain outlet, and clean-out caps.



Model FR2-3
Patented

WATER QUALITY REQUIREMENTS

Incoming water in excess of 3.0 grains of hardness per gallon (GPG) (.75 grains of hardness per liter) must be treated and softened before being supplied to water heater(s). Water containing over 3.0 GPG (.75 GPL) will decrease the efficiency and reduce the operating life of the unit.

Note: Product failure caused by liming or sediment buildup is not covered under warranty.

FOOD RETHERMALIZING REQUIREMENTS

NSF Standard 4 has added performance requirements for food rethermalizing. The requirements mirror the requirements for food rethermalizing in the FDA Food Code. The basic requirement is that food reaches a temperature of 165°F (74°C) in a time period of two hours or less.

Appliances that are manufactured for the purpose of rethermalizing food will need to meet these performance requirements in order to be listed to NSF Standard 4.

Hatco sells a heating unit specifically made to be used for food rethermalizing, however, the heating unit is designed to be incorporated into a hot water bath rethermalizer. Hatco does not supply the vessel that contains the water, nor the system which determines how food is placed and held in the vessel. The Hatco FR2 unit simply attaches to the bottom of the vessel and supplies hot water to the vessel.

Hatco does supply sizing recommendations to enable the appliance manufacturer to correctly size the FR2 unit to the vessel. However, there are variables in the way that the vessel is manufactured that affect its ability to pass the NSF performance requirements. The Hatco FR2 unit is listed with NSF for construction only. Due to the fact that the FR2 is only a portion of a larger system, it is impossible to do performance testing until the FR2 unit is incorporated onto the water vessel.

The result is that it is the responsibility of the vessel manufacturer to have the entire rethermalizing appliance tested and listed in accordance with NSF Standard 4. Simply hanging an NSF listed FR2 unit on the appliance does not transfer NSF listing to the entire appliance.



HATCO CORPORATION P.O. Box 340500 Milwaukee, WI 53234-0500 U.S.A.
(800) 558-0607 • (414) 671-6350 • Fax (800) 543-7521 • Int'l. Fax (414) 671-3976
www.hatcocorp.com • E-mail: equipsales@hatcocorp.com

Form No. FR2 Spec Sheet

Printed in U.S.A.
June 2009



FR2 HYDRO-HEATER FOOD RETHERMALIZERS / BAIN-MARIE HEATERS

Models FR2-3, -4, -6 FR2-3B, -4B, -6B, -9B

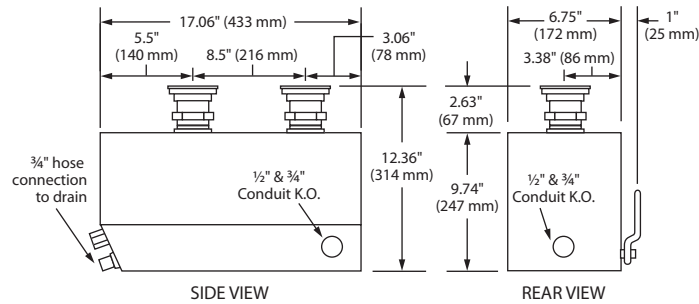

SPECIFICATIONS

Model	kW	Phase	Shipping Weight
FR2-3	3	1	24 lbs. (11 kg)
FR2-4	4	1	24 lbs. (11 kg)
FR2-6	6	1	27 lbs. (12 kg)
FR2-3B	3	Balanced 3	24 lbs. (11 kg)
FR2-4B	4	Balanced 3	24 lbs. (11 kg)
FR2-6B	6	Balanced 3	27 lbs. (12 kg)
FR2-9B	9	Balanced 3	27 lbs. (12 kg)

DIMENSIONS

7.75"W x 17.06"D x 12.36"H (197 x 433 x 314 mm).

VOLTAGE

208 or 240 volts, 50/60 Hz.

PLUG CONFIGURATIONS (FR2-3 and FR2-4 only)

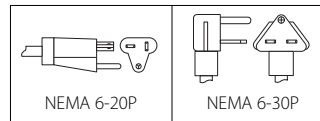

FR2-3: 208 or 240 volts (uses NEMA 6-20P).

FR2-4: 208 volts (uses NEMA 6-30P, 240 volts uses NEMA 6-20P, NEMA 6-30P – Canada).

SIZING INFORMATION

For a Bain-Marie or Steam Table: **MINIMUM 750 WATTS PER SQUARE FOOT** (0,8 watts per sq. cm) of vessel top.

For a Food Rethermalizer: **MINIMUM 2000 WATTS PER SQUARE FOOT** (2,2 watts per sq. cm) of vessel top.

Use one FR2 for a Bain-Marie up to 6' (1829 mm) long. Over 6' (1829 mm), minimum two required.

MUST BE INSTALLED WITH A PERFORATED WATER BAFFLE. This baffle is **not supplied** with heater. The FR2 should be positioned with no more than 3' (914 mm) on either side when mounted in holding vessel. Consult factory or installation manual for fabricating details.

OPTIONS (NOT FOR RETROFIT)

- Stainless Steel Body and Base
- Auto-fill Solenoid
- Remote Mounted Control
- Security Package

ACCESSORIES

- 4' (1219 mm) Cord with Plug (NEMA 6-20P) and Receptacle (NEMA 6-20R) (FR2-3 only)
- 4' (1219 mm) Cord with Plug (NEMA 6-30P) and Receptacle (NEMA 6-30R) (FR2-4 only)
- Flush Hose, Cleaning Brush, Stopper, and Adapter

PRODUCT SPECS

Hydro-Heater Food Reconstitutor/Bain-Marie Heater

The electric heater designed to hold foods in the bain-marie or heat and hold frozen foods in a food reconstitutor shall be a Hydro-Heater Model ... as manufactured by the Hatco Corporation, Milwaukee, WI 53234 U.S.A.

With 24/7 service (U.S. and Canada only), the Hatco Model FR2 shall be rated at ... kW, ... volts, ... phase. The heater shall be complete with all internal plumbing and wiring ready for external installation to the bottom of the holding vessel.

The heater shall consist of 1 to 3 stainless steel tubes wrapped with external heating elements. Each tube may be accessed for cleaning purposes. The unit may be emptied easily by a convenient drain.

The heater shall be equipped with an electronic temperature controller adjustable from 140°F to 190°F (60° to 88°C), an on-off switch, a low-water cut-off, and a digital temperature display.

The heater shall consist of powdercoated black hammertone front and body (or optional stainless steel body and base).