

## MODEL # VIAP AT

### SPECIFICATIONS

The VIAP-AT is a drop-in air pan with an air tower which provides higher air coverage for taller product. It is cooled by circulating a curtain of refrigerated air over the product in the display area to enable precise temperature control and maximum cold transfer to the food product.



Available depths:  28"

Available lengths:  30 1/2"  43 1/4"  56"  68 7/8" (DIMENSIONS REPRESENT OUTSIDE FLANGES)

Available heights:  4" \*

### STANDARD FEATURES

- 304 Stainless Steel Exterior
- Adjustable Deck Pan to Convert to Slanted Display
- Easy Removable Deck Pans for Cleaning
- Adapter Bars for Standard Full-Size Pans (Pans Not Included)
- Programmable Digital Refrigeration Controller
- Self-Contained Refrigeration with Pull Out Compressor Housing
- Forced Air Cooling System
- Lift Up Evaporator
- ETL Listed in Accordance with UL 471 and NSF 7 Standards
- Environmentally Safe Refrigerant

### OPTIONAL FEATURES

- Integrations Modular Counter (Consult Factory)
- Sneeze Guards (Consult Factory)
- Rear Air Ventilation Kit
- Front Air Ventilation Kit for Units Against Wall
- Remote Refrigeration
- 5 Year Compressor Warranty

### WHEN ORDERING, PLEASE SPECIFY:

APPLICATION: \_\_\_\_\_

REFRIGERATION TYPE: \_\_\_\_\_

MODEL	L	D	H	PANS	HP	VOLT	AMP	NEMA PLUG	WT	CUT-OUT SIZE	REFRIG.
VIAP-2-0-R-SC-AT	30 1/2	28	4*	2	1/4	115V	3.9	5-15P	191	28 3/4 x 26 1/4	134A
VIAP-3-0-R-SC-AT	43 1/4	28	4*	3	1/3	115V	4.7	5-15P	240	41 5/8 x 26 1/4	134A
VIAP-4-0-R-SC-AT	56	28	4*	4	3/8	115V	6.1	5-15P	277	54 3/8 x 26 1/4	134A
VIAP-5-0-R-SC-AT	68 7/8	28	4*	5	1/2	115V	6.9	5-15P	362	67 1/8 x 26 1/4	134A

\*Height is the air tower above the counter.

PLEASE NOTE: This model does not include a surrounding flange. Must be supported from bottom. Contact factory for cut out and installation information.

# VIENNA AIR PAN W/AIR TOWER

PROJECT: \_\_\_\_\_

TOLL FREE: 800-525-3692

## MODEL # VIAP AT

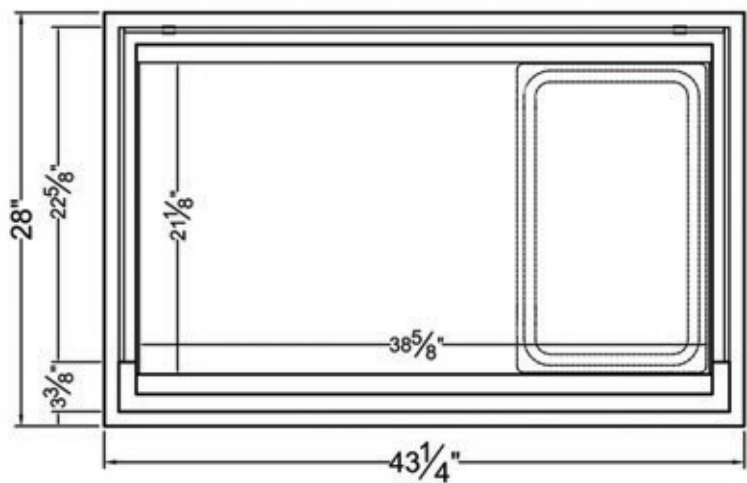
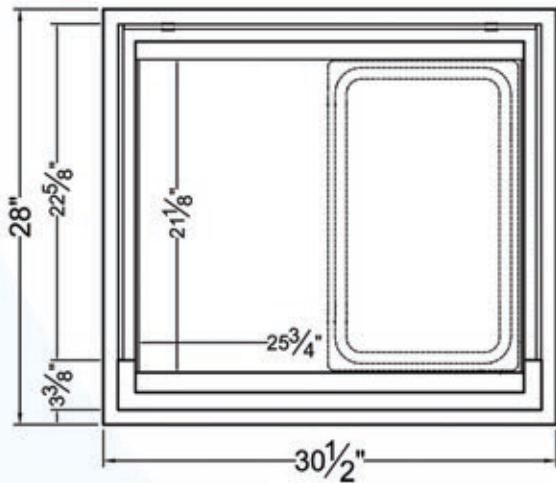
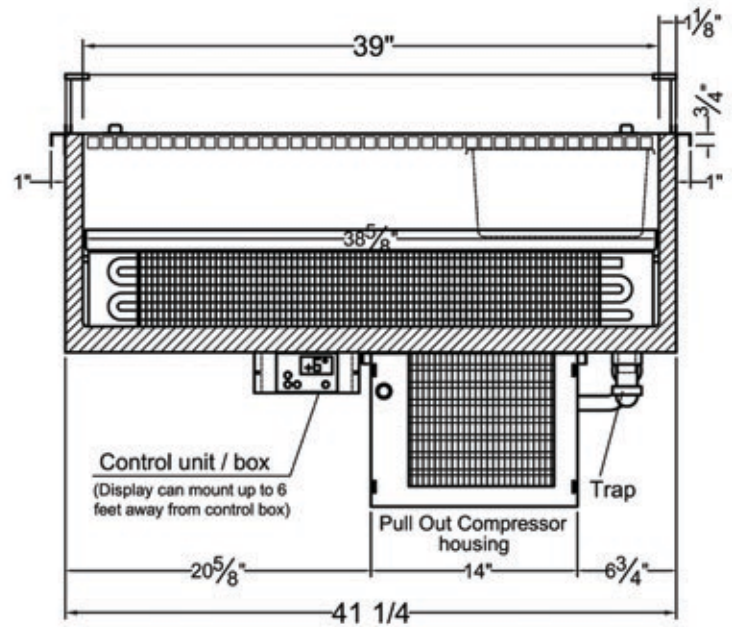
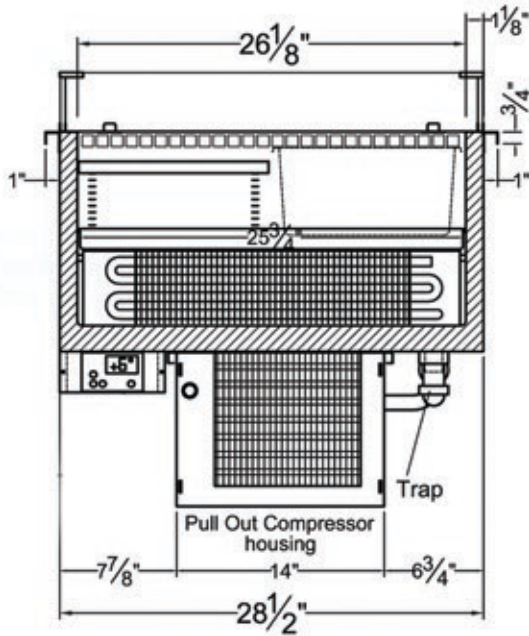

## VIAP-2-0-R-SAT

## VIAP-3-0-R-SC-AT

CALL TOLL FREE: 800-525-3692 (609-714-2330)

FAX: 609-714-2331 [www.rpiindustries.com](http://www.rpiindustries.com)

220 ROUTE 70, MEDFORD, NJ 08055

# VIENNA AIR PAN W/AIR TOWER

PROJECT: \_\_\_\_\_  
TOLL FREE: 800-525-3692

## MODEL # VIAP AT

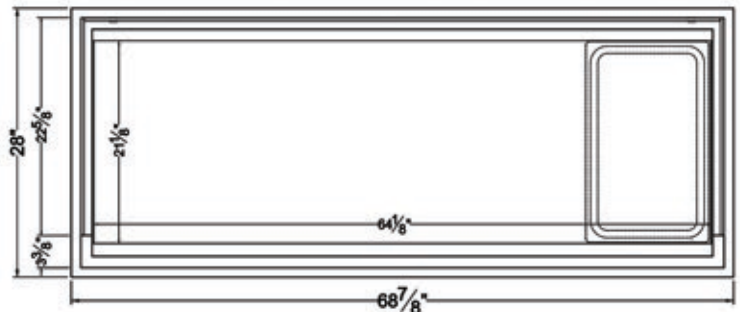
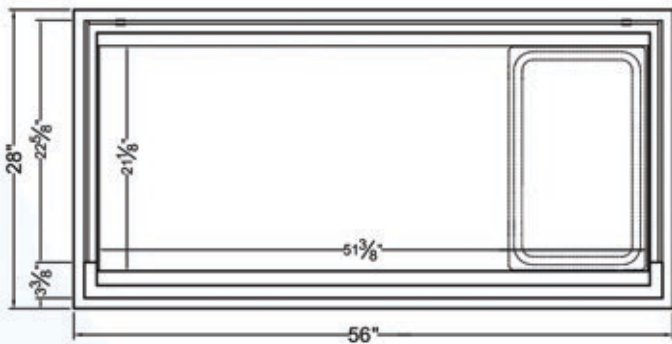
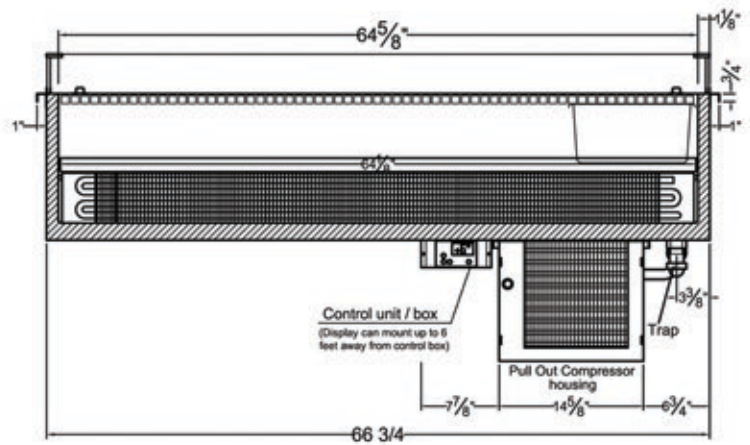
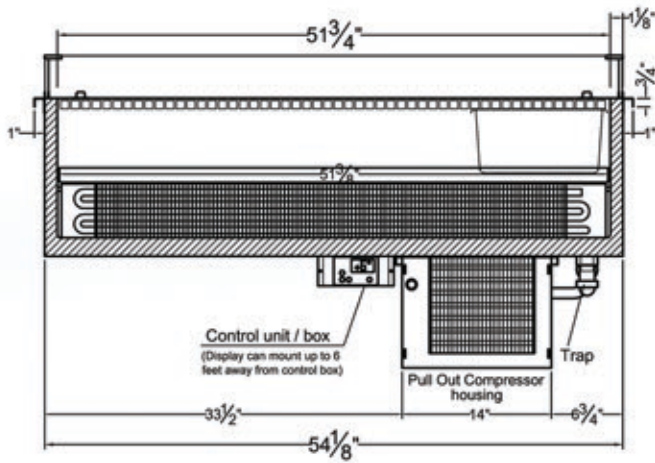

## VIAP-4-0-R-SC-AT

## VIAP-5-0-R-SC-AT

CALL TOLL FREE: 800-525-3692 (609-714-2330)  
FAX: 609-714-2331 [www.rpiindustries.com](http://www.rpiindustries.com)  
220 ROUTE 70, MEDFORD, NJ 08055



# VIENNA AIR PAN W/AIR TOWER

PROJECT: \_\_\_\_\_

TOLL FREE: 800-525-3692

## MODEL # VIAP AT

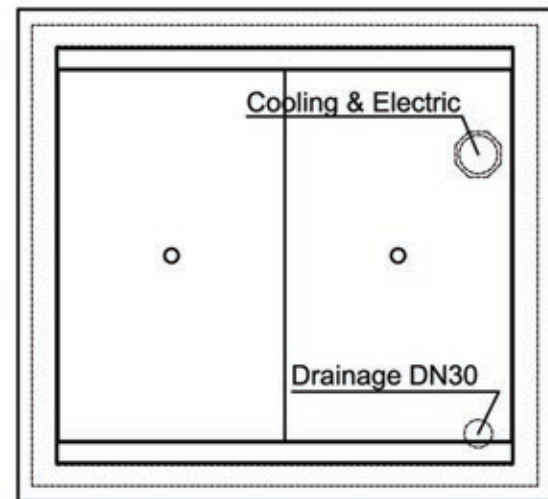
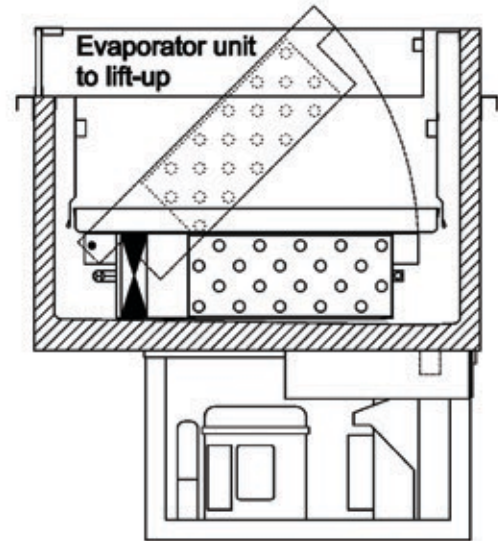
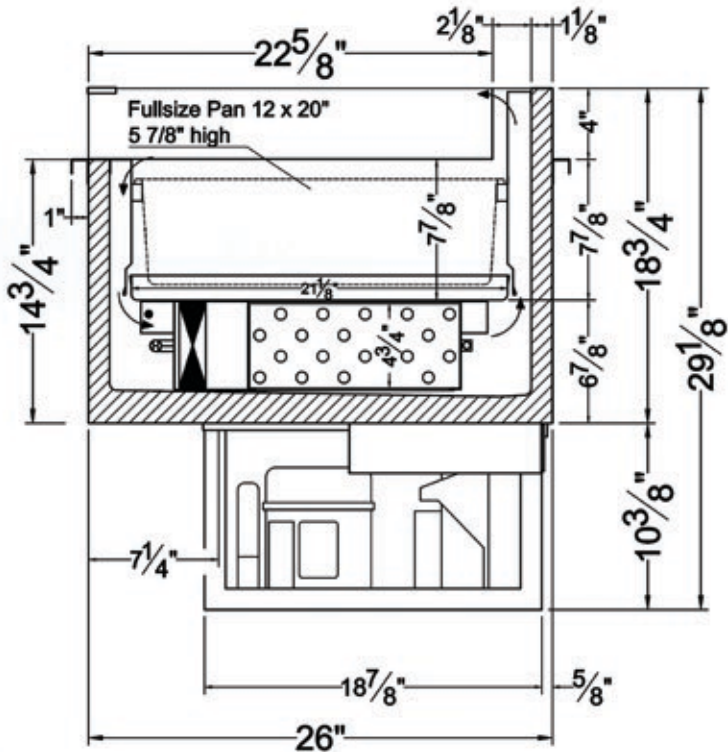

## Electrical & Plumbing locations



Conforms to UL Standard 471,  
and NSF Standard 7; Certified  
To CSA Standard C22.2 No. 120

1. A 1" diameter drain is provided. The drain **MUST** be run to a floor drain **AT TIME OF INSTALLATION**.

2. Front and Rear ventilation louvers, each at least 25" W x 20" H, **MUST** be provided in the cabinet or counter and located so to provide full ventilation for the condensing unit. Refrigeration System is designed so air will flow rear to front. Unobstructed air flow must be maintained to ensure unit performance and maintain warranty.

3. RPI Merchandiser is designed for use in stores where ambient temperatures and humidity do not exceed 75 Degrees Fahrenheit and 55% R.H. Locate away from direct sunlight, rapid air currents and extreme temperature changes. Exposure to air currents from ceiling fans, air conditioning diffusers, ovens, etc. will disrupt the case air curtain and refrigerated zone. Refrigerated Displays are designed to maintain pre-chilled products. Adding or loading warm products above 41 Degrees Fahrenheit can affect the temperature in the entire cabinet.

RPI in line with its policy to continually improve its products reserves the right to change materials and specifications without notice.

CALL TOLL FREE: 800-525-3692 (609-714-2330)

FAX: 609-714-2331 [www.rpiindustries.com](http://www.rpiindustries.com)

220 ROUTE 70, MEDFORD, NJ 08055

