

# Southern PRIDE

## SPECIFICATIONS MODEL DH-65



Capacities on these products may vary based on physical shape, weight of product and the method of loading.

### COOKING CAPACITIES FOR THE DH-65

St. Louis Ribs (2.75 lb.)	65 pieces	179 lb. total
Baby Back Ribs (1.75 lb.)	65 pieces	114 lb. total
Following Capacities Possible with Optional Flat Racks		
Pork Butt (7 lb.)	30 pieces	210 lb. total
Chicken (3 lb.)	40 pieces	120 lb. total
Brisket (12 lb.)	15 pieces	180 lb. total

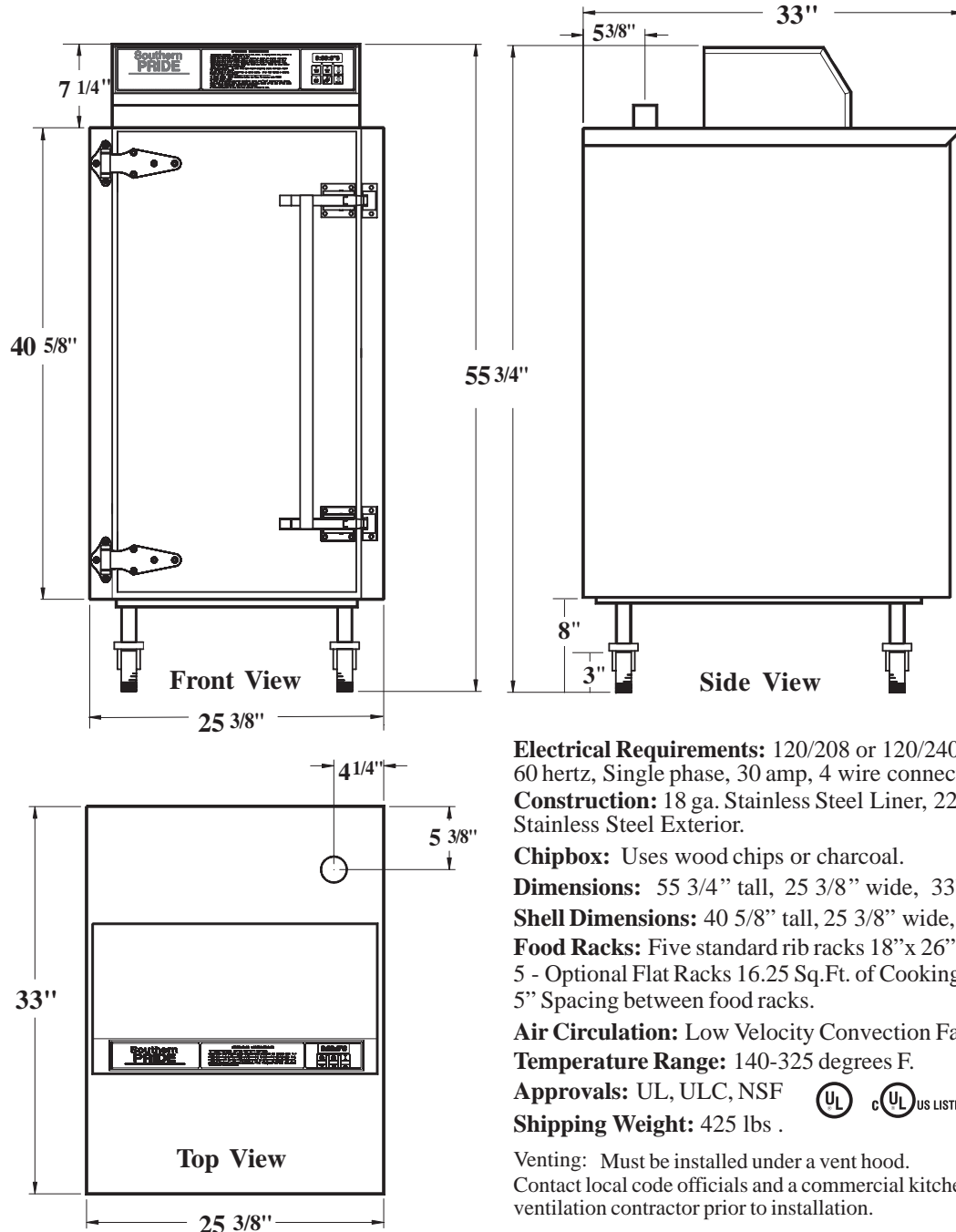

**Electrical Requirements:** 120/208 or 120/240 volts AC, 60 hertz, Single phase, 30 amp, 4 wire connection.

**Construction:** 18 ga. Stainless Steel Liner, 22 ga. Stainless Steel Exterior.

**Chipbox:** Uses wood chips or charcoal.

**Dimensions:** 55 3/4" tall, 25 3/8" wide, 33" deep

**Shell Dimensions:** 40 5/8" tall, 25 3/8" wide, 33" deep

**Food Racks:** Five standard rib racks 18"x 26"

5 - Optional Flat Racks 16.25 Sq.Ft. of Cooking Surface.  
 5" Spacing between food racks.

**Air Circulation:** Low Velocity Convection Fan.

**Temperature Range:** 140-325 degrees F.

**Approvals:** UL, ULC, NSF



**Shipping Weight:** 425 lbs .

Venting: Must be installed under a vent hood.

Contact local code officials and a commercial kitchen ventilation contractor prior to installation.

# Southern PRIDE

Southern Pride Distributing, L.L.C.

472 South Mill St. Alamo, TN 38001

www.southernpride.com sales@sopride.com service@sopride.com parts@sopride.com

Sales: 800-851-8180 Sales Fax: 731-696-3180 Service: 800-437-2679 Service Fax: 618-993-0378