

Project	Quantity	Item #
Model Specified:		CSI Section 11400

Roll-In/Roll-Thru Refrigerated-Heated Models/Self-Contained



Includes Traulsen's patented INTELA-TRAUL® control



Model RIDH232LUT-FHS
(shown with standard left/right hinging)

Two Section Models, 32" Deep



Stainless Exterior & Interior

Roll-In Model
Roll-Thru Model

RIDH232LUT-FHS
RIDH232LPUT-FHS



Stainless Exterior, Anodized Aluminum Interior

Roll-In Model
Roll-Thru Model

AIDH232LUT-FHS
AIDH232LPUT-FHS

The R & A Series represent Traulsen's Top-of-the-Line product offering. The roll-in and roll-thru refrigerated/heated models are all designed to offer convenient storage for 66" high racks. Each is supplied standard with such high quality features as balanced refrigeration systems, microprocessor controls, communications ability and stainless steel exteriors. Additionally, they offer the widest range of optional accessories to choose from, and can be specified for use with many different applications, including: Foodservice, Correctional, Institutional, Export, etc.

Standard Product Features

- R-Series: Stainless Steel Exterior & Interior
- A-Series: Stainless Steel Exterior/Anodized Aluminum Interior
- INTELA-TRAUL® Microprocessor Control System
- One-Time Start-Up Temperature Adjustment Feature & ON/OFF Switch (for heated compartment only)
- Balanced, Self-Contained Refrigeration System Using R-134a
- Scroll Blower Type Evaporator Fan
- Biased Return Air Duct
- Full Length Stainless Steel Doors With Locks
- Self-Closing Doors With Stay Open Feature At 120 Degrees
- Guaranteed For Life Cam-Lift Hinges
- Guaranteed For Life Horizontal Work Flow Door Handle
- Standard Door Hinging: 232L = Left/Right, F & R: 232LP = Left/Right (other hings available)
- Automatically Activated Incandescent Lights
- Stainless Steel Breaker Caps
- Accommodates Roll-In Racks Up To 66" High (provided by others)
- Automatic Non-Electric Condensate Evaporator
- Magnetic Snap-In Door Gaskets
- Gasket Protecting Metal Door Liner
- Controllable Anti-Condensate Door Perimeter Heaters
- Thermostatic Expansion Valve Metering Device
- Stainless Steel One-Piece Louver Assembly & Heater Guards
- 9' Cord & Plug Attached
- Stainless Steel Interior Rack Guides
- Stainless Steel Threshold Ramps
- One Year Parts And Labor Warranty
- Two Year Control Warranty (parts and labor)
- Five Year Compressor Warranty

Options & Accessories

- Stainless Steel Finished Back With Rear Louvers (reach-in models only)
- Re-Hinging Feature For Doors
- Wire Shelf Package For Roll-In/Roll-Thru Model (includes three shelves per section)
- Additional Wire Shelves For Above
- Stainless Steel Shelf Package For Roll-In/Roll-Thru Model (includes three shelves per section)
- Additional Stainless Steel Shelves For Above
- Locking Hasps (padlocks supplied by others)
- Kool Klad Exterior Laminate Decor
- Prison/Correctional Facilities Options
- Remote Applications (see spec sheet TR35837 for details)
- Two Year Service/Labor Warranty Available



Listed by Underwriters Laboratories Inc., and classified by Underwriters Laboratories Inc., in accordance with ANSI/NSF7.

AW-03118

Approval: _____



TRAULSEN
4401 BLUE MOUND RD.
PHONE 1 (800) 825-8220
Website: www.traulsen.com

FT. WORTH, TX 76106
FAX-MKTG. 1 (817) 624-4302

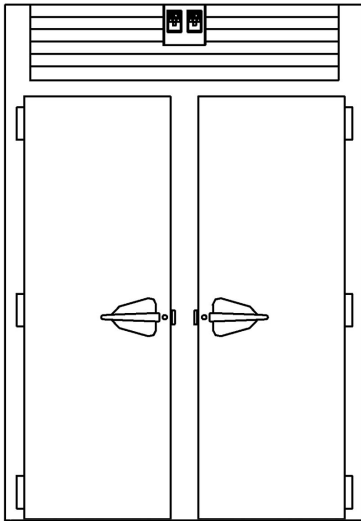

Elevation - R/AIDH232LUT

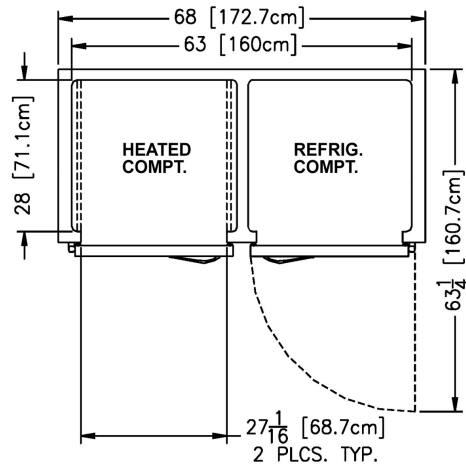

Plan - R/AIDH232LUT

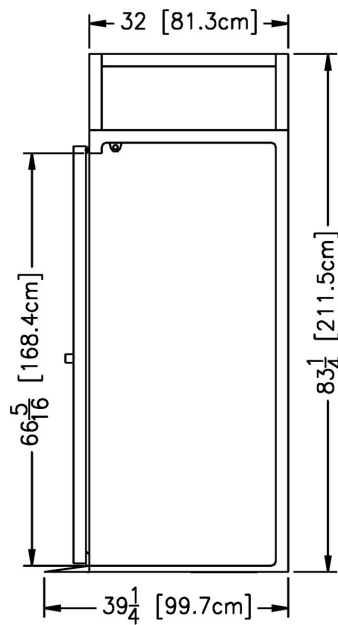

Section - R/AIDH232LUT

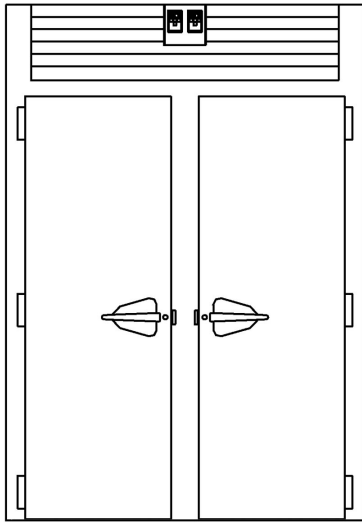

Elevation - R/AIDH232LPUT

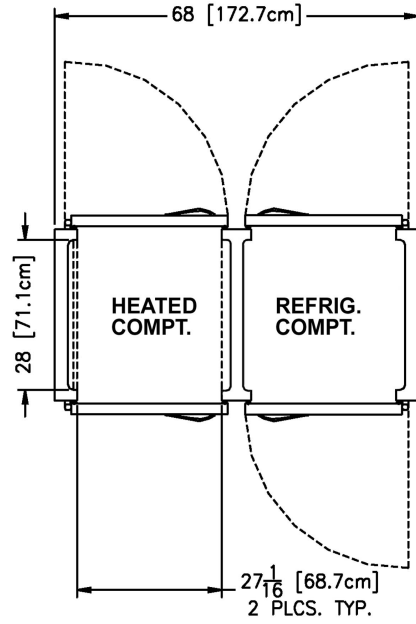

Plan - R/AIDT232LPUT

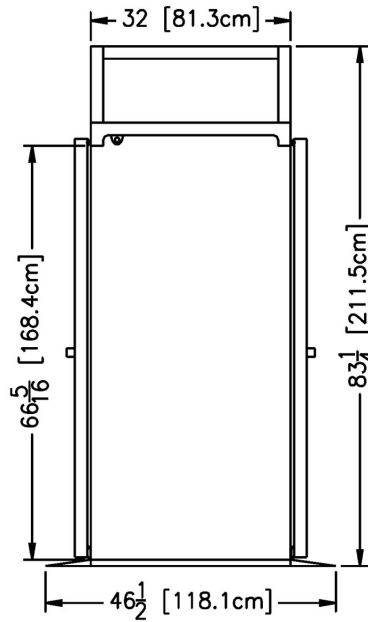

Section - R/AIDH232LPUT



TRAULSEN
 4401 BLUE MOUND RD.
 PHONE 1 (800) 825-8220
 Website: www.traulsen.com

FT. WORTH, TX 76106
 FAX-MKTG. 1 (817) 624-4302

Project	Quantity	Item #
Model Specified:		CSI Section 11400

Specifications

Construction, Hardware and Insulation

Cabinet exterior, including front, one piece sides, louver assembly and doors are constructed of heavy gauge stainless steel. Cabinet interior and door liners are constructed of stainless steel. Exterior cabinet top and back are constructed of heavy gauge aluminized steel. The exterior bottom is constructed of heavy gauge galvanized steel and insulated with ¾" of resilient cork. A readily attachable stainless steel ramp is provided.

Doors are equipped with heavy-duty, extruded wiper gasket for sealing to bottom ramp, removable plug cylinder locks and guaranteed for life cam-lift, gravity action, self-closing metal, glide hinges with stay open feature at 120 degrees. Hinges include a switch to automatically activate the interior incandescent lighting. Guaranteed for life, work flow door handle is mounted horizontally over recess in door which limits protrusion from door face into aislesways.

Easily removable for cleaning, vinyl magnetic door gasket assures tight door seal. Anti condensate heaters are located behind each door opening.

Cabinet and door contains high density, non-CFC, foamed in place polyurethane insulation.

DIMENSIONAL DATA	R/AIDH232LUT	R/AIDH232LPUT
Cabinet Type	Roll-In	Roll-Thru
Net capacity total cu. ft.	74.3 (2105 cu l)	80.2 (2272 cu l)
Length - overall in.	68 (172.7 cm)	68 (172.7 cm)
Depth - overall in.	35 ⁹ / ₁₆ (90.3 cm)	39 ¹ / ₈ (99.4 cm)
Depth - over body in.	32 (81.3 cm)	32 (81.3 cm)
Depth - door(s) open 90° in.	63 ¹ / ₄ (160.7 cm)	94 ¹ / ₂ (240.0 cm)
Clear door width in.	27 ¹ / ₁₆ (68.7 cm)	27 ¹ / ₁₆ (68.7 cm)
Clear door height in.	66 ⁹ / ₁₆ (168.4 cm)	66 ⁹ / ₁₆ (168.4 cm)
Height - overall	83 ¹ / ₄ (211.5 cm)	83 ¹ / ₄ (211.5 cm)
Rack Capacity (66" high by others)	2	2
RIDH Net Wt. lbs.	700 (318kg)	775 (352 kg)
AIDH Net Wt. lbs.	600 (272 kg)	670 (304 kg)
ELECTRICAL DATA		
Voltage	208/115/60/1	208/115/60/1
Feed wires with Ground	4	4
Heater Wattage @ 208V	1500	1500
Full load amperes	13.5	13.5
REFRIGERATION DATA		
Refrigerant	R-134a	R-134a
BTU/HR H.P. ¹	2220 (1/8 HP)	2220 (1/8 HP)

NOTES

NOTE: Figures in parentheses reflect metric equivalents.

1= Based on a 90 degree F ambient and 20 degree F evaporator.

2= For approximate remote weights deduct 40 lbs. from respective net or gross weight. For other information on remote models, please refer to spec sheet TR35837.

Refrigeration System

A top mounted, self-contained, balanced refrigeration system using R-134a refrigerant is conveniently located behind the one piece louver assembly. These models feature an easy to clean front facing condenser, thermostatic expansion valve, air-cooled hermetic compressor, plenum effect blower coil, large, high humidity evaporator coil located outside the food zone and a top mounted non-electric condensate evaporator.

Biased return air duct protects against introduction of warm kitchen air, promoting even temperature maintenance and efficient operation.

A 9' cord and plug is provided standard. Standard operating temperatures are 34 to 38°F for the refrigerator compartment and 135 to 180°F for the heated compartment.

Heating System

A low watt density, serpentine style, heater is employed for the generation of electric heat. Low velocity air is forced across its large surface area to efficiently move heat radiating away from these through a down-air distribution duct, where it is then evenly distributed throughout the cabinet, assuring the proper holding environment for hot food product, without drying. A vent, located at the top of the cabinet, is included for positive humidity control.

Controller

The easy to use water resistant INTELA-TRAUL® microprocessor control system is supplied standard. Unit is NAFEM Data Protocol communication (NDP) ready. Optional hardware required to be NDP compliant. Third party software required for network connection. It includes a 3-Digit LED Display, Fahrenheit or Celsius Temperature Scale Display Capability, and an RS485 data port. In addition it includes audio/visual alarms for: Hi/Lo Cabinet Temperature, Door Open, Clean Condenser, Evaporator Coil and Discharge Line Sensor Failures, and Power Supply Interruption. A separate control is provided for both the refrigerated and heated compartments.

Interior

Readily removable, interior-mounted, stainless steel guides for rack are provided for protection. Maximum rack size with wheels inboard of frame is 27" wide by 29" deep by 66" high. Racks supplied by others.

Warranties

Both a one year parts and labor warranty and a five year compressor warranty (self-contained models only) are provided standard. An optional 2nd year extended parts and labor warranty is also available. In addition the INTELA-TRAUL® controls are warranted by a two year parts and labor warranty.



Equipped With One NEMA L14-20P Plug

NOTE: Full load amps and plug style may vary depending on electrical options chosen and condensing unit employed.

REQUIRED CLEARANCES

In order to assure optimum performance, the condensing unit **MUST** have an adequate supply of air for cooling purposes. Therefore, the operating location must either have a minimum of 12" clearance overhead of the condensing unit or allow for unrestricted air flow at the back of the unit. Clearance of at least 12" above is required in order to perform certain maintenance tasks.

NOTE: When ordering please specify: Voltage, Hinging, Door Size, Options and any additional warranties.

Continued product development may necessitate specification changes without notice.

Part No. TR35786 (revised 4/10)

TRAULSEN
4401 BLUE MOUND RD.
PHONE 1 (800) 825-8220
Website: www.traulsen.com

FT. WORTH, TX 76106
FAX-MKTG. 1 (817) 624-4302

