

Project	Quantity	Item #
Model Specified:		CSI Section 11400

### "D-Width" Reach-In Refrigerator Models/Self-Contained



Includes Traulsen's patented  
INTELA-TRAUL® control



Model RHT132DUT-FHS  
(shown with optional casters)



Stainless Exterior  
& Interior



Stainless Exterior,  
Anodized Alumi-  
num Interior

### One & Two Section Models, 26" Deep

1-Section Full Length Door Model	RHT132DUT-FHS
2-Section Full Length Door Model	RHT232DUT-FHS
1-Section Half Length Door Model	RHT132DUT-HHS
2-Section Half Length Door Model	RHT232DUT-HHS

1-Section Full Length Door Model	AHT132DUT-FHS
2-Section Full Length Door Model	AHT232DUT-FHS
1-Section Half Length Door Model	AHT132DUT-HHS
2-Section Half Length Door Model	AHT232DUT-HHS

The R & A Series represent Traulsen's Top-of-the-Line product offering. The "D-Width" reach-in refrigerator models are all designed to offer maximum interior storage capacity within a narrow 24" or 48" footprint. Each is supplied standard with such high quality features as balanced refrigeration systems, microprocessor controls, communications ability and stainless steel exteriors. Additionally, they offer the widest range of optional accessories to choose from, and can be specified for use with many different applications, including: Foodservice, Correctional, Institutional, Export, etc.

### Standard Product Features

- R-Series: Stainless Steel Exterior & Interior
- A-Series: Stainless Steel Exterior/Anodized Aluminum Interior
- INTELA-TRAUL® Microprocessor Control System
- Balanced, Self-Contained Refrigeration System Using R-134a
- Scroll Blower Type Evaporator Fan
- Biased Return Air Duct
- Full or Half Length Stainless Steel Doors With Locks
- Self-Closing Doors With Stay Open Feature At 120 Degrees
- Guaranteed For Life Cam-Lift Hinges
- Guaranteed For Life Horizontal Work Flow Door Handle
- Standard Door Hinging: 132D = Right, 232D = Left/Right (other hinging not available for two-section models)
- Automatically Activated Incandescent Lights
- Stainless Steel Breaker Caps
- Three Adjustable Wire Shelves Per Section, Supported On Shelf Pins (installed at the factory)
- Automatic Non-Electric Condensate Evaporator
- Magnetic Snap-In Door Gaskets
- Gasket Protecting Metal Door Liner
- Controllable Anti-Condensate Door Perimeter Heaters
- Thermostatic Expansion Valve Metering Device
- Stainless Steel One-Piece Louver Assembly
- 9' Cord & Plug Attached
- Set of Four (4) 6" High Adjustable Stainless Steel Legs
- One Year Parts And Labor Warranty
- Two Year Control Warranty (parts and labor)
- Five Year Compressor Warranty

### Options & Accessories

- Stainless Steel Finished Back With Rear Louvers
- No. 1 Type Tray Slides To Accommodate either (1) 18" x 26" or (2) 14" x 18" Pans
- No. 2 Type Tray Slides To Accommodate (1) 18" x 26" Pans
- Additional Wire Shelves or Optional Stainless Steel Shelves
- Optional 220/50/1 or 208/115/60/1 Voltages
- Kool Klad Exterior Laminate Decor
- Set of Four (4) 4-5/8" or 6" High Casters In Lieu of Legs
- Other Support Options: 4-1/2" High Base or 6" High Kickplate
- Remote Applications (see form TR35837 for more details)
- Remote For Use With 20°F Glycol System
- Clear Glass Door(s) In Place Of One Or More Solid Door(s)
- Two Year Service/Labor Warranty Available



Listed by Underwriters Laboratories Inc.,  
to U.S. and Canadian safety standards and  
Listed by NSF International.

Approval: \_\_\_\_\_



TRAULSEN  
4401 BLUE MOUND RD.  
PHONE 1 (800) 825-8220  
Website: www.traulsen.com

FT. WORTH, TX 76106  
FAX-MKTG. 1 (817) 624-4302

Project	Quantity	Item #
Model Specified:		CSI Section 11400

## Specifications

### Construction, Hardware and Insulation

Cabinet exterior front, one piece sides, louver assembly and doors are constructed of 20 gauge stainless steel with #4 finish. Cabinet interior and door liners are constructed of stainless steel (anodized aluminum in the A-Series). The exterior cabinet top, back and bottom are constructed of heavy gauge aluminized steel. A set of four (4) adjustable 6" high stainless steel legs are included.

Doors are equipped with a gasket protecting metal door pan, removable plug cylinder locks and guaranteed for life cam-lift, gravity action, self-closing metal, glide hinges with stay open feature at 120 degrees. Hinges include a concealed switch to automatically activate the interior incandescent lighting. Guaranteed for life, work flow door handles are mounted horizontally over recess in door which limits protrusion from door face into aiseways. Doors have seamless, polished metal corners.

Easily removable for cleaning, vinyl magnetic door gasket assures tight door seal. Anti condensate heaters are located behind each door opening.

Both the cabinet and door(s) are insulated with an average of 2" thick high density, non-CFC, foamed in place polyurethane.

DIMENSIONAL DATA	R/AHT132DUT	R/AHT232DUT
Net capacity cu. ft.	17.7 (501 cu l)	42.0 (1190 cu l)
Length - overall in.	24 (61.0 cm)	48 (121.9 cm)
Depth - overall in.	35 (88.8 cm)	35 (88.8 cm)
Depth - less handle in.	33 $\frac{3}{4}$ (84.4 cm)	33 $\frac{3}{4}$ (84.4 cm)
Depth - over body in.	32 (81.3 cm)	32 (81.3 cm)
Depth - door open 90° in.	54 $\frac{3}{4}$ (139.1 cm)	54 $\frac{3}{4}$ (139.1 cm)
Clear door width in.	18 $\frac{5}{8}$ (47.3 cm)	19 $\frac{9}{16}$ (49.7 cm)
Clear half-door height in.	27 $\frac{1}{2}$ (69.9 cm)	27 $\frac{1}{2}$ (69.9 cm)
Clear full-door height in.	57 $\frac{5}{8}$ (146.3 cm)	57 $\frac{5}{8}$ (146.3 cm)
Height - overall on 6" legs	83 $\frac{3}{4}$ (211.5 cm)	83 $\frac{3}{4}$ (211.5 cm)
RHT Net Wt. lbs. <sup>1</sup>	330 (150 kg)	574 (260 kg)
AHT Net Wt. lbs. <sup>1</sup>	290 (132 kg)	446 (202 kg)
No. Standard Shelves	3	6
Shelf area sq. ft. <sup>2</sup>	14.2 (1.3 sq m)	31.6 (2.9 sq m)
ELECTRICAL DATA		
Voltage	115/60/1	115/60/1
Feed wires with Ground	3	3
Full load amperes	8.0	10.4
REFRIGERATION DATA		
Refrigerant	R-134a	R-134a
BTU/HR H.P. <sup>3</sup>	2220 (1/3 HP)	4200 (1/2 HP)

### NOTES

NOTE: Figures in parentheses reflect metric equivalents.

1= For shipping weights and dimensions please refer to form TR35875.

2= Area of standard shelf compliment only, does not include storage area of additional shelves or available on cabinet bottom.

3= Based on a 90 degree F ambient and 20 degree F evaporator. For information on remote models, please refer to form TR35837.



### Equipped With One NEMA 5-15 P Plug

NOTE: Full load amps and plug style may vary depending on electrical options chosen and condensing unit employed.

### REQUIRED CLEARANCES

In order to assure optimum performance, the condensing unit **MUST** have an adequate supply of air for cooling purposes. Therefore, the operating location must either have a minimum of 12" clearance overhead of the condensing unit or allow for unrestricted air flow at the back of the unit. Clearance of at least 12" above is required in order to perform certain maintenance tasks.

### Refrigeration System

A top mounted, self-contained, balanced refrigeration system using R-134a refrigerant is conveniently located behind the one piece louver assembly. It features an easy to clean front facing condenser, thermostatic expansion valve, air-cooled hermetic compressor, plenum effect blower coil, large, high humidity evaporator coil located outside the food zone and a top mounted non-electric condensate evaporator. Biased return air duct protects against introduction of warm kitchen air, promoting even temperature maintenance and efficient operation. A 9' cord and plug is provided. Standard operating temperature is 34 to 38°F.

### Controller

The easy to use water resistant INTELA-TRAUL® microprocessor control system is supplied standard. Unit is NAFEM Data Protocol communication (NDP) ready. Optional hardware required to be NDP compliant. Third party software required for network connection. It includes a 3-Digit LED Display, Fahrenheit or Celsius Temperature Scale Display Capability, and an RS485 data port. In addition it includes audio/visual alarms for: Hi/Lo Cabinet Temperature, Door Open, Clean Condenser, Evaporator Coil and Discharge Line Sensor Failures, and Power Supply Interruption.

### Interior

Standard interior arrangements include three (3) wire shelves per section, mounted on shelf pins. Shelves are full-width, and do not have any large gaps between them requiring the use of "bridge" or "junior shelves." Recommended load limit per shelf should not exceed 225 lbs. Optional tray slides may be purchased in combination with, or in lieu of these. Both standard and optional interior arrangements are completely installed at the factory.

### Warranties

Both a one year parts and labor warranty and a five year compressor warranty (self-contained models only) are provided standard. An optional 2<sup>nd</sup> year extended parts and labor warranty is also available. In addition the INTELA-TRAUL® control is warranted by a two year parts and labor warranty.

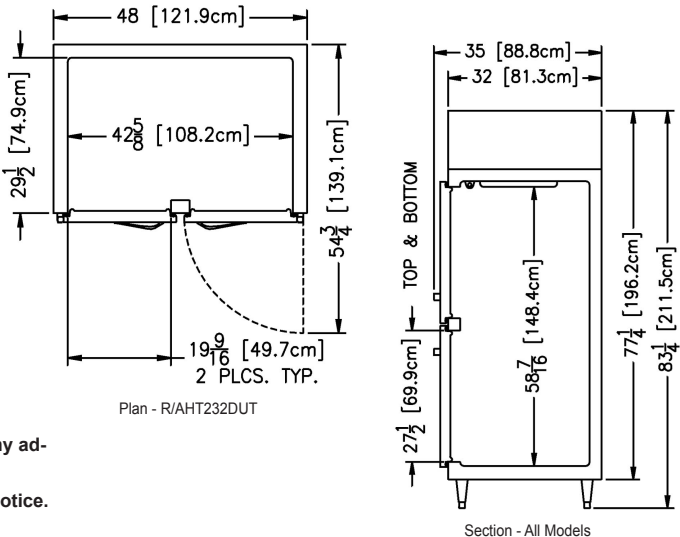
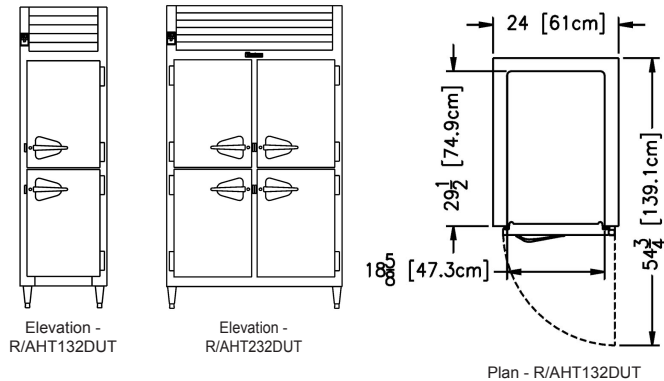

NOTE: When ordering please specify: Voltage, Hinging, Door Size, Options and any additional warranties.

Continued product development may necessitate specification changes without notice. Part No. TR35758 (revised 4/10)

TRAULSEN  
4401 BLUE MOUND RD.  
PHONE 1 (800) 825-8220  
Website: www.traulsen.com

FT. WORTH, TX 76106  
FAX-MKTG. 1 (817) 624-4302

