

FRYERS

VULCAN**1VK85 SERIES
FREE STANDING GAS FRYER**

Model 1VK85C

**SPECIFICATIONS**

85 - 90 lbs. capacity free standing gas fryer, Vulcan-Hart Model No. (1VK85A) (1VK85D) (1VK85C). Stainless steel cabinet. Set of four 6" adjustable casters (2 locking). Stainless steel fry tank with FivePass™ heat transfer system yielding 78% thermal efficiency and "V" shaped cold zone. SoftStart™ ignition system using 35,000 BTU's to extend oil life during start up. 95,000 BTU/hr. input. 1¼" full port ball type drain valve. Twin fry baskets with plastic coated handles. Solid state analog knob control, digital, or programmable computer control systems all standard with electronic matchless ignition. Tank brush and clean-out rod included.

Overall dimensions:

21"w x 34⅜"d x 47⅞"h. Working height 36¼".

CSA design certified. NSF listed.

SPECIFY TYPE OF GAS WHEN ORDERING

- Natural Gas.
 Propane Gas.

SPECIFY ALTITUDE

The 1VK85 Series fryer does not require any special adjustments for varying altitudes ranging from 0 - 10,000 feet for either Natural or Propane gas.

1VK85A: Solid state analog knob control behind the door. Accurate temperature control 200° to 390°F. User selectable fat melt modes. Electronic ignition.

1VK85D: Accurate temperature control 200-390°F with digital display. Fast recovery. Cook with compensating time or actual time. Electronic ignition. Digital temperatures: Fahrenheit or Celsius. Three melt modes. Two count-down timers. Auto boil-out mode.

1VK85C: Programmable computer controls with digital character display. 10 menu timers display product name and cook times. Offline programming of menu items uploaded through USB interface, software included. Accurate temperature control 200-390°F with digital display. Fast recovery. Cook with compensating time or actual time. Electronic ignition. Digital temperatures: Fahrenheit or Celsius. Three melt modes.

STANDARD FEATURES

- 90,000 BTU/hr. input.
- Energy saving SoftStart™ ignition system extends oil life while requiring lower BTU's.
- Energy efficient FivePass™ heat transfer system yielding 78% thermal efficiency.
- Stainless steel fry tank, 85 - 90 lb. capacity. Includes 10 year limited tank warranty.
- 1¼" full port ball type drain valve.
- Stainless steel cabinet.
- Set of four 6" adjustable (2 locking) casters.
- Twin fry baskets with plastic coated handles.
- Hi-limit shut-off.
- Electronic matchless ignition.
- Tank brush and clean-out rod.
- One year limited parts and labor warranty.

ACCESSORIES

- FRYMATE-VX21S add-on frymate.
- Stainless steel tank cover – doubles as a work surface top.
- Connecting Kit(s) – Connects two fryers together (brackets, grease strip and hardware included).
- Single large basket – 18¾"w x 17¼"d x 5½"h.
- Set of twin baskets – 8¾"w x 16¾"d x 6"h.
- ¾" Flexible gas hose with quick disconnect.
- 10" high stainless steel removable splash guard.

OPTIONS

- Second year extended limited parts and labor warranty

VULCAN

a division of ITW Food Equipment Group LLC

P.O. Box 696 ■ Louisville, KY 40201 ■ Toll-free: 1-800-814-2028 ■ Local: 502-778-2791 ■ Quote & Order Fax: 1-800-444-0602



**1VK85 SERIES
FREE STANDING GAS FRYER**

INSTALLATION INSTRUCTIONS

1. A combination valve with pressure regulator is provided with this unit. Natural Gas 4.0" (102 mm) W.C. Propane Gas 10.0" (279 mm) W.C.
2. An adequate ventilation system is required for Commercial Cooking Equipment. Information may be obtained by writing to the National Fire Protection Association, Batterymarch Park, Quincy, MA 02269. When writing refer to NFPA No. 96.
3. All models require a 6" (152 mm) clearance at both sides and rear adjacent to combustible construction. All models require a 16" (407 mm) minimum clearance to adjacent open top burner units.

4. This appliance is manufactured for commercial installation only and is not intended for home use.

SERVICE CONNECTIONS:

- Ⓟ 1/2" (13 mm) ID and 3/4" (19 mm) OD rear gas connection.
- Ⓜ NEMA 5-15P 120 Volt cord & plug supplied with fryers.

NOTE: In line with its policy to continually improve its product, Vulcan reserves the right to change materials and specifications without notice.

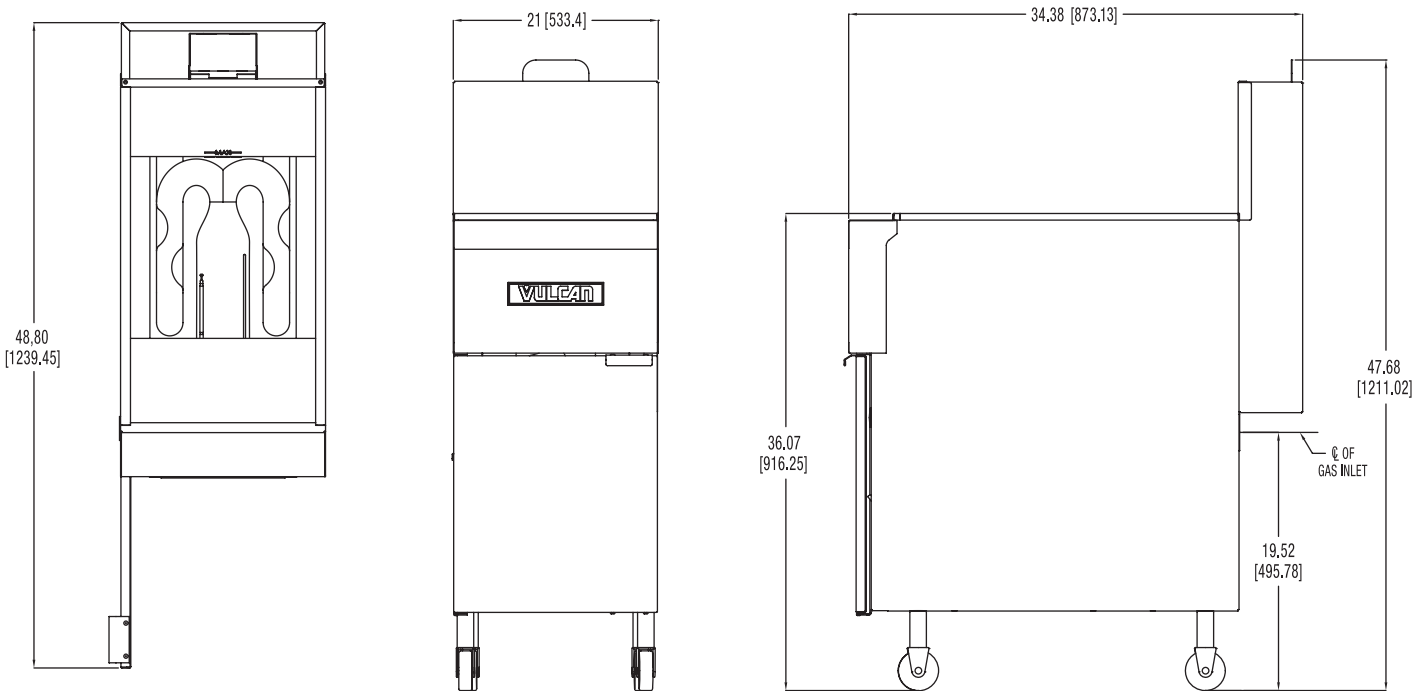

MODEL	Width	Depth	Overall Height	Working Height	Tank Size	BTU/hr.	Fry Comp. Capacity	Approx. Shipping Weight
1VK85A 1VK85D 1VK85C	21"	34 ³ / ₈ "	47 ¹ / ₈ "	36 ¹ / ₄ "	19.5" x 18"	90,000	85 - 90 lbs.	265 lbs.

This appliance is manufactured for commercial use only and is not intended for home use.



a division of ITW Food Equipment Group LLC

P.O. Box 696 ■ Louisville, KY 40201 ■ Toll-free: 1-800-814-2028 ■ Local: 502-778-2791 ■ Quote & Order Fax: 1-800-444-0602