

RESTAURANT RANGES

VULCAN**36" ELECTRIC RESTAURANT RANGE
3 HOT TOPS**

Model EV36-S-3HT-208

**SPECIFICATIONS**

36" wide electric restaurant range, Vulcan Model No. EV36-S-3HT-208. Fully MIG welded aluminized steel frame for added durability. Stainless steel front, sides, back riser, plate shelf and 6" adjustable legs. Three 12" x 24" thermostatically controlled hot top sections, 5 KW input. Full width pull out crumb tray located beneath the cooking top. Comes with one standard oversized oven. Oven interior measures 26½"w x 26¾"d x 14"h. Comes with one oven rack and three rack positions. Oven door is heavy duty with an integrated door hinge/spring mechanism, requiring no adjustments. Top browning heat control. Thermostat adjusts from 200°F to 500°F. Oven controls are protected from heat in an insulated side compartment. Requires 208, 240 or 480 volt, 1 or 3 phase power supply. All ranges shipped in 3 phase and are field convertible to single phase.

Exterior Dimensions:

34¾"d x 36"w x 58"h on 6" adjustable legs

- EV36-S-3HT-208** 3 Hot Tops / Standard Oversized Oven / 208V
- EV36-S-3HT-240** 3 Hot Tops / Standard Oversized Oven / 240V
- EV36-S-3HT-480** 3 Hot Tops / Standard Oversized Oven / 480V

STANDARD FEATURES

- Fully MIG welded aluminized steel frame for added durability
- Stainless steel front, sides, back riser, shelf and legs
- Full width pullout crumb tray
- Three 12" x 24" thermostatically controlled hot top sections, 5 KW input
- 5 kW oven with top browning control
- Thermostat adjusts from 200°F to 500°F
- Cool to the touch control knobs and oven handle
- One oven rack and three rack positions
- 18" x 26" sheet pans fit side to side and front to back
- Requires 208, 240 or 480 volt, 1 or 3 phase power supply. (Ranges shipped in 3 phase and are field convertible to single phase)
- One year limited parts and labor warranty

ACCESSORIES (Packaged & Sold Separately)

- Extra oven rack with two rack guides
- Set of four casters (two locking)
- 10" stainless steel stub back

Note: Due to excessive heat an ESB36 salamander broiler cannot be mounted on this range.

VULCAN

a division of ITW Food Equipment Group LLC

P.O. Box 696 ■ Louisville, KY 40201 ■ Toll-free: 1-800-814-2028 ■ Local: 502-778-2791 ■ Quote & Order Fax: 1-800-444-0602



36" ELECTRIC RESTAURANT RANGE 3 HOT TOPS

INSTALLATION INSTRUCTIONS

Clearances from Combustible Construction	Rear	Sides
Range Only	0"	0"
Range and ESB Salamander Broiler	2"	8"

Ranges incorporating hot top sections are 0 inches sides and 0 inches rear to non-combustibles and 6 inches sides and 6 inches rear to combustible constructions.

Clearance Note: Electric Ranges are 0 inches, sides and 0 inches rear from combustible and non-combustible constructions except when hot top sections are incorporated.

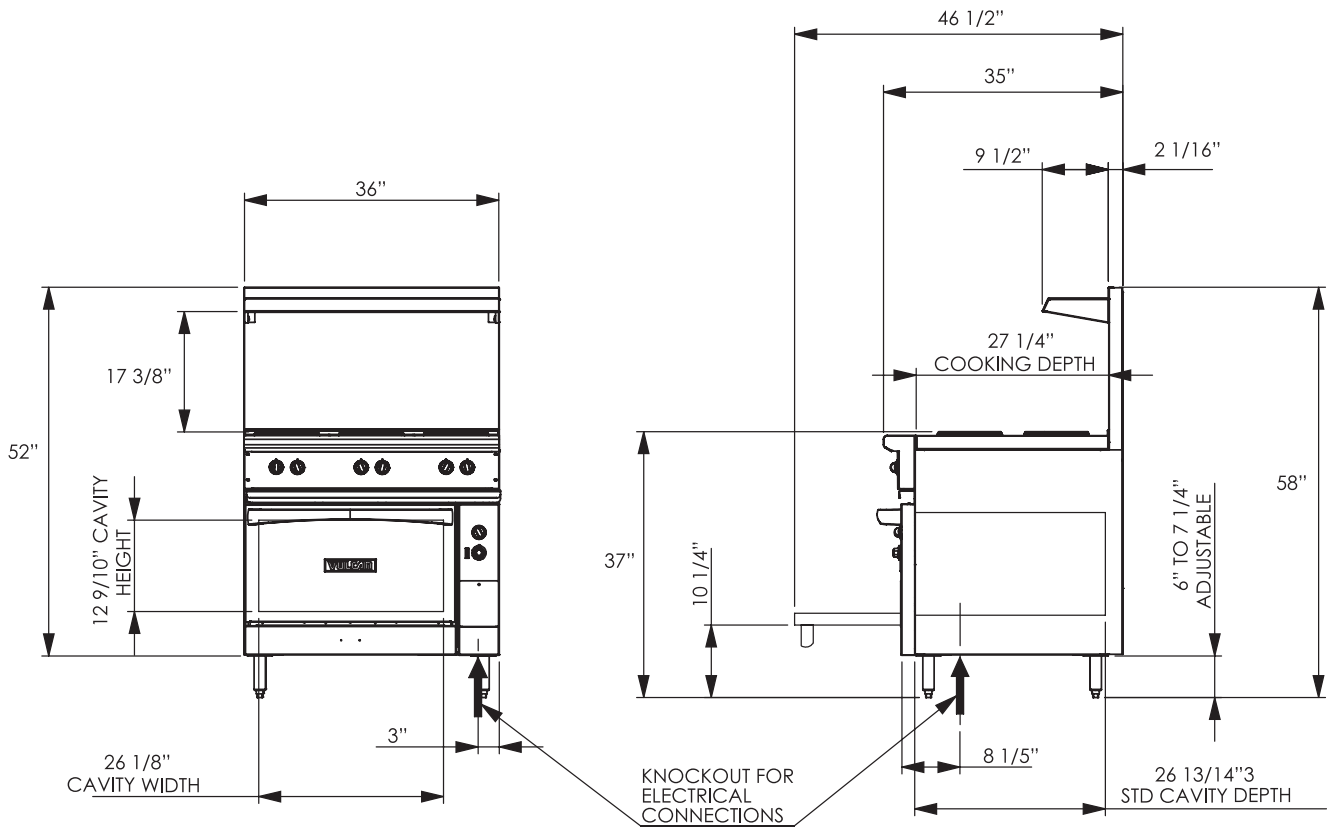

AVAILABLE VOLTAGES - 208, 240 OR 408 VOLT - 1 OR 3 PHASE																
3 PHASE LOADING					NOMINAL AMPS PER LINE WIRE											
MODEL NUMBER	TOTAL CONNECTING KW	KW PER PHASE			3 PHASE									1 PHASE		
					208 VOLT			240 VOLT			480 VOLT			1 PHASE		
		X-Y	Y-Z	X-Z	X	Y	Z	X	Y	Z	X	Y	Z	208V	240V	480V
EV36-S-3HT-208	20.0	5.0	10.0	5.0	41.6	62.5	62.5	--	--	--	--	--	--	96.2	--	--
EV36-S-3HT-240	20.0	5.0	10.0	5.0	--	--	--	36.1	54.1	54.1	--	--	--	--	83.3	--
EV36-S-3HT-480	20.0	5.0	10.8	5.0	--	--	--	--	--	--	18.05	27.05	27.0	--	--	41.65

This appliance is manufactured for commercial use only and is not intended for home use.



a division of ITW Food Equipment Group LLC

P.O. Box 696 ■ Louisville, KY 40201 ■ Toll-free: 1-800-814-2028 ■ Local: 502-778-2791 ■ Quote & Order Fax: 1-800-444-0602