

RESTAURANT RANGES

VULCAN**36" ELECTRIC
RESTAURANT RANGE**

Model EV36-S-6FP-208
shown with optional casters

**SPECIFICATIONS**

36" wide electric restaurant range, Vulcan Model No. EV36-S-6FP-208. Fully MIG welded aluminized steel frame for added durability. Stainless steel front, sides, back riser, plate shelf and 6" adjustable legs. Six 9½" round French plates, 2 kW input per plate. Full width pull out crumb tray located beneath the cooking top. Comes with one standard oversized oven. Oven interior measures 26½"w x 26⅜"d x 14"h. Comes with one oven rack and three rack positions. Oven door is heavy duty with an integrated door hinge / spring mechanism, requiring no adjustments. 5 kW input. Top browning heat control. Thermostat adjusts from 200°F to 500°F. Oven controls are protected from heat in an insulated side compartment. Requires 208, 240 or 480 volt, 1 or 3 phase power supply. All ranges are shipped in 3 phase and are field convertible to single phase.

Exterior Dimensions:

34¾"d x 36"w x 58"h on 6" adjustable legs

- EV36-S-6FP-208** 6 French Plates / Standard Oversized Oven / 208V
- EV36-S-6FP-240** 6 French Plates / Standard Oversized Oven / 240V
- EV36-S-6FP-480** 6 French Plates / Standard Oversized Oven / 480V

STANDARD FEATURES

- Fully MIG welded aluminized steel frame for added durability
- Stainless steel front, sides, back riser, shelf and legs
- Six 9½" round, 2 kW French plates with infinite heat control switches
- Full width pull out crumb tray
- 5 kW oven with top browning control
- Thermostat adjusts from 200°F to 500°F
- Cool to the touch control knobs and oven handle
- One oven rack and three rack positions
- 18" x 26" sheet pans fit side to side and front to back
- Requires 208, 240 or 480 volt, 1 or 3 phase power supply. (Ranges shipped in 3 phase and are field convertible to single phase)
- One year limited parts and labor warranty

ACCESSORIES (Packaged & Sold Separately)

- Extra oven rack with two rack guides
- Set of four casters (two locking)
- 10" stainless steel stub back
- ESB36 salamander broiler
- Reinforced high shelf for ESB36 salamander broiler

VULCAN

a division of ITW Food Equipment Group LLC

P.O. Box 696 ■ Louisville, KY 40201 ■ Toll-free: 1-800-814-2028 ■ Local: 502-778-2791 ■ Quote & Order Fax: 1-800-444-0602



36" ELECTRIC RESTAURANT RANGE

INSTALLATION INSTRUCTIONS

Clearances from Combustible Construction	Rear	Sides
Range Only	0"	0"
Range and ESB Salamander Broiler	2"	8"

Ranges incorporating hot top sections are 0 inches sides and 0 inches rear to non-combustibles and 6 inches sides and 6 inches rear to combustible constructions.

Clearance Note: Electric Ranges are 0 inches, sides and 0 inches rear from combustible and non-combustible constructions except when hot top sections are incorporated.

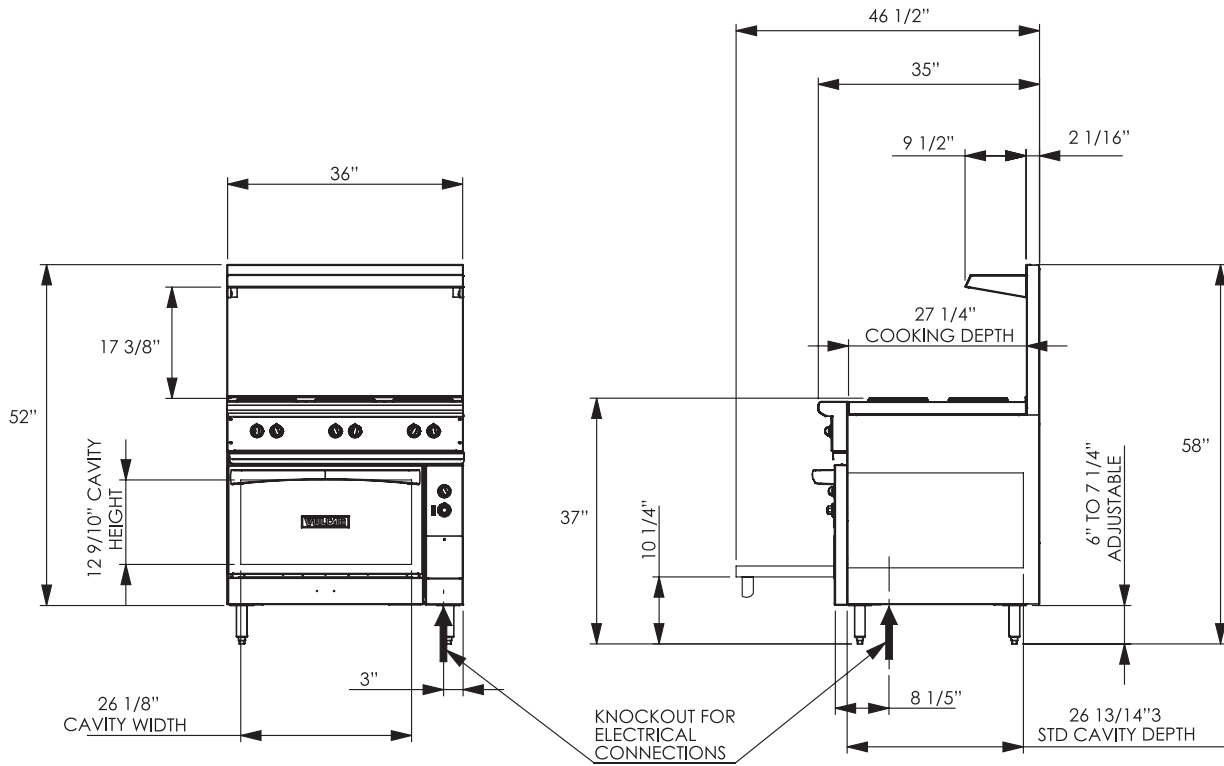

AVAILABLE VOLTAGES - 208 OR 240 VOLT - 1 OR 3 PHASE																
3 PHASE LOADING					NOMINAL AMPS PER LINE WIRE											
MODEL NUMBER	TOTAL CONNECTING KW	KW PER PHASE			3 PHASE									1 PHASE		
					208 VOLT			240 VOLT			480 VOLT					
		X-Y	Y-Z	X-Z	X	Y	Z	X	Y	Z	X	Y	Z	208V	240V	480V
EV36-S-6FP-208	17.0	4.0	8.0	5.0	37.5	50.0	54.1	--	--	--	--	--	--	81.7	--	--
EV36-S-6FP-240	17.0	4.0	8.0	5.0	--	--	--	32.5	43.3	46.9	--	--	--	--	70.8	--
EV36-S-6FP-480	17.0	4.0	8.0	5.0	--	--	--	--	--	--	16.25	21.65	23.45	--	--	35.4

This appliance is manufactured for commercial use only and is not intended for home use.



a division of ITW Food Equipment Group LLC

P.O. Box 696 ■ Louisville, KY 40201 ■ Toll-free: 1-800-814-2028 ■ Local: 502-778-2791 ■ Quote & Order Fax: 1-800-444-0602