



FEC120 Product Features and Specs

Description

The Fast Eddy's™ by Cookshack FEC120 smoker is a 100% wood pellet smoker with the Cookshack IQ5 electronic control system. The FEC120 features an offset firebox and a convection fan to circulate smoke and heat for steady temperatures throughout the unit. It is the perfect choice for operations who cook moderate amounts of smoked foods or barbecue.

How It Works

- Heat and smoke are supplied by 100% wood pellets
- Offset firebox and convection fan circulates smoke and heat for even temperatures
- Drippings exit the bottom of the smoker into a removable drip pan for a clean, safe operation

IQ5 Controller

- Digital controller
- Includes 8 programmable, customizable cooking presets
- Alarm cycle
- LCD display
- USB port for downloading up to 512 hours of cook time onto a FAT formatted USB flash drive



- Features 3-stage, 2-stage and probe mode cooking options
- Optional meat probe allows the user to set the smoker to a desired internal meat temperature and then automatically cycles into rest when the temperature is met

Efficient

- Tough double-walled stainless steel construction surrounds 850°F Spin-Glas® insulation
- Retains heat and remains cool to the touch on the outside

Pellets

- Pellets are clean burning, produce very little ash and create low creosote buildup
- Approved by all major cooking competition sanctioning bodies

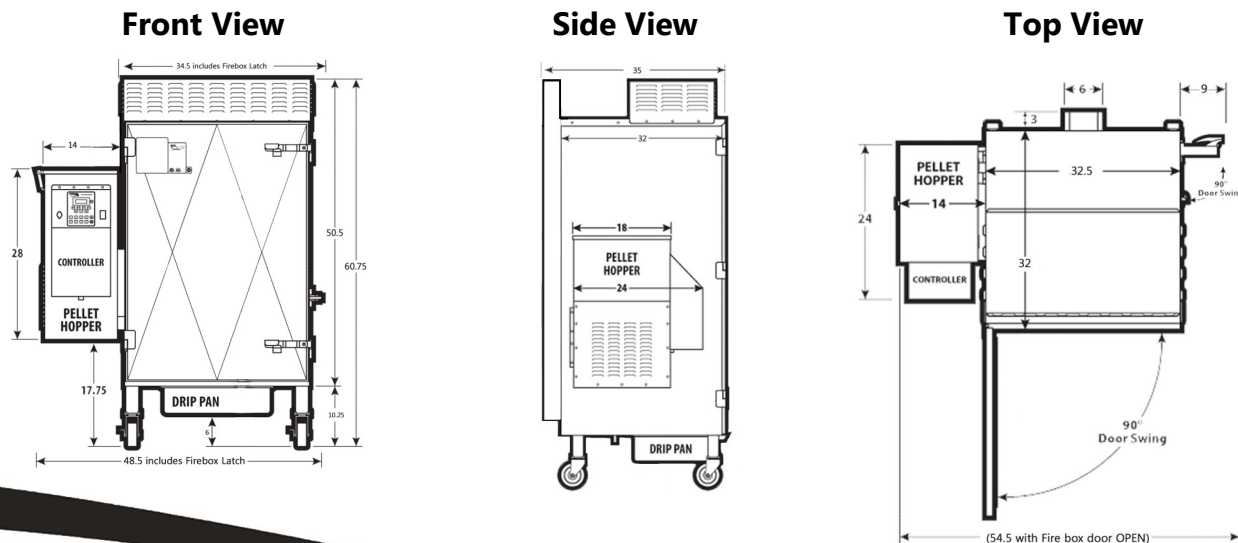

FEC120 Venting Requirements

Before installation, contact local code officials and a commercial kitchen ventilation contractor to determine codes and permit requirements. Unit must be installed per state and local fire codes and meet NFPA 96 in the US.

The unit requires a separate 120 volt, 20 amp circuit and grounded in accordance to the National Electric Code ANSI/NFPA 70-1990 (or comparable codes outside the United States).

The Fast Eddy's™ by Cookshack FEC120 and FEC240 must be installed under a commercial hood with fire suppression applicable to local code (NFPA 96).

Adequate makeup air is required for safe operation.

| FEC120 Specifications | |
|------------------------|---|
| Outside Dimensions | 48.5"W (54.5"W w/ firebox door open) x 60.75"H x 35"D |
| Food Capacity | 150 lbs. pork butts, 120 lbs. brisket, 90 lbs. ribs, or 30 whole chickens per load |
| Cooking Area | 13.5 sq. ft. (1,955 sq. in.) |
| Shelves | (5) nickel-plated steel 23" X 17" shelves |
| Appx Fuel Consumption | 1lb. of pellets per hour at 250°F |
| Appx Cost of Operation | \$6.21 per 12 hour cycle at average setting (includes pellet cost and electric) |
| Temperature Range | 160°F to 400°F |
| Electrical | 7 amps @ 120 VAC; 36,000 BTU burner; electronically-controlled IQ5 thermostat; auto-start draft fan; power cord approximate length is 53" (±6") |
| Fuel Source | 100% wood pellets |
| Pellet Hopper Capacity | 35 lbs. |
| Shipping Weight | 560 lbs. |
| Standard Equipment | 5 grills, side racks, drip pan, pre-installed casters, operator's manual, registration card, cookbook, 40 lbs. pellets and Cookshack Spice Kit |
| Optional Accessories | Smoker Cover, Meat Probe, Pepper Popper Grills, Jerky Rods, Rib Racks and Stainless Steel Shelves |
| Warranty | Cookshack products are backed by a 2 year limited warranty including 90 days full parts and labor. |