



Your Solutions Partner

DUKE

Serving & Production Solutions

QSR • FAST CASUAL • C-STORES



The *modular* counters & equipment mix you require for your operation's *unique* needs.



Duke's expertise in modular counters, utility walls, metal cabinetry, production centers, and worktables provide your operation with the mix it needs to create the optimal environment for creating, preparing and serving your customers food. We're experts at evaluating your operations flow for areas of improvement in speed and quality. We consider everything you need to ensure you deliver a consistent product, quality, and aesthetic to the customers you serve. In fact, our award-winning modular production centers combine industry-leading holding and storage with advanced ergonomics in a compact footprint, that allows your crews to work within even the smallest of places, improving speed, increasing efficiency, reducing waste, and ensuring proper food temperature in hot kitchen environments.

Key features you'll see in our product lines:

- 1 Patented Thermal Technologies
- 2 High Ambient Refrigeration
- 3 Energy Efficient Waterless Design
- 4 Multiple Integrated Cover Options
- 5 Efficient Smallware and Packaging Storage
- 6 Modular Flexibility
- 7 Highly Customizable Finish and Top Options
- 8 Ergonomically Designed Work Stations
- 9 Durable Construction
- 10 Merchandising Solutions including:
 - Kiosk for digital ordering stations
 - Built-in/ on mobile order pickup stations
 - Display solutions for sides, drinks, and desserts

FlowMetrix

Duke's proprietary **FlowMetrix** process helps you identify and unblock your workflow bottlenecks by mapping the current state of your kitchen through video, time and motion studies, counting steps and touches, and menu and workflow diagrams.

Using **FlowMetrix** to reconfigure your workstations will increase your throughput, speed of service, food quality and consistency. And you know what this leads to: **increased profits and customer satisfaction!**

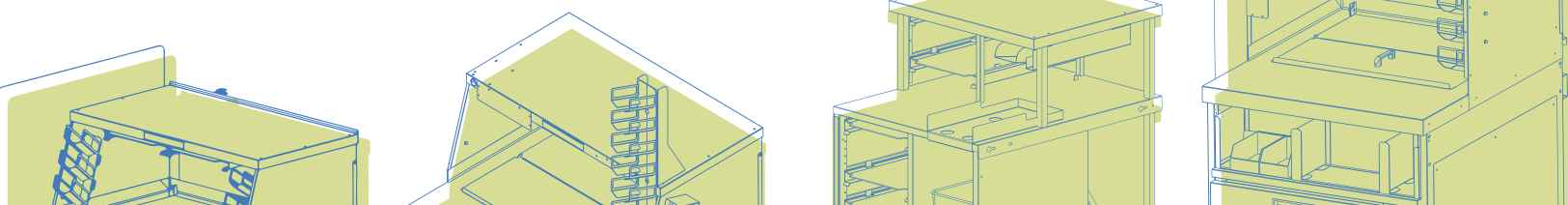

Which Solutions Are Right For You?

Modular Serving Counters

Elegance and functionality combined, modular counters allow for customization to your operations unique needs.



Utility Distribution Walls

Provide pleasing aesthetics while running all your utilities through a protected and secure channel. Modular equipment rolls in and out easily for cleaning and maintenance.



Metal Cabinetry



Worktables



Production Centers

Modular Work Stations • Improve Speed of Service • Enhanced Ergonomics • Superior Holding Quality
Food Waste Reduction • Designed for Chain Environments • Award Winning Technology

Customer Specific Needs

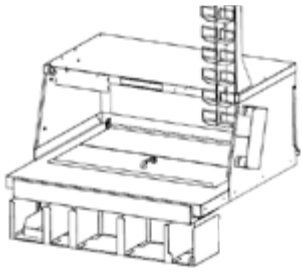

+ =

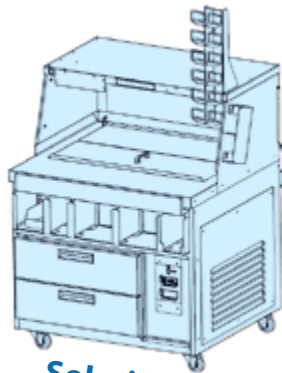

Solution

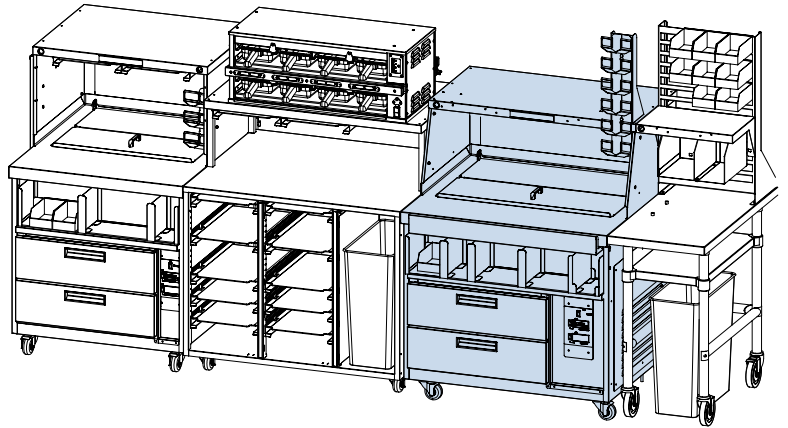

Standard Duke Base

CENTER LINE



BACKLINE



Contact Us To Customize Your Solution!

TOLL FREE:
1.800.735.3853

PHONE:
314.231.1130



Your Solutions Partner

www.dukemfg.com



Your Solutions Partner

**DUKE CORPORATE
UNITED STATES, CANADA**

2305 N. Broadway
St. Louis, MO 63102

Toll Free: 800.735.3853
Phone: 314.231.1130
Fax: 314.231.5074

**EUROPE, MIDDLE EAST,
AFRICA, RUSSIA**

Duke Manufacturing CR s.r.o.
P3 Logistic Parks
P3 Prague D11, Zeleneč,
Mstětice 1052,
250 91 Zeleneč, Mstětice,
Středočeský kraj Hala DC2
Czech Republic

Calling from United Kingdom
and Ireland

Tel: +44.(0)1395.234140
Fax: +44.(0)1395.234154

ASIA

No. 3 Building,
Lane 28, Yu Lv Road,
Malu Town, Jiading District
Shanghai 201801, China

Phone:
+86.21.59153525/59153526
Fax: +86.21.33600628